

Instructions for Use

Profipress XL

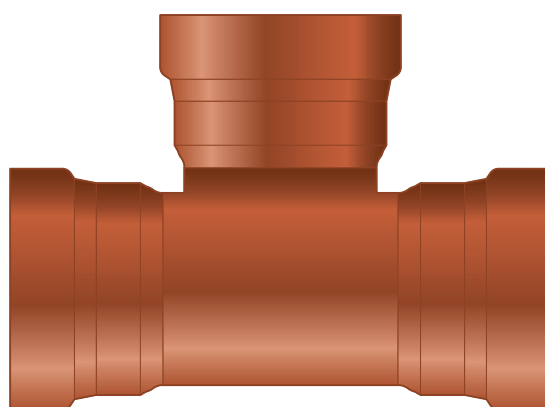
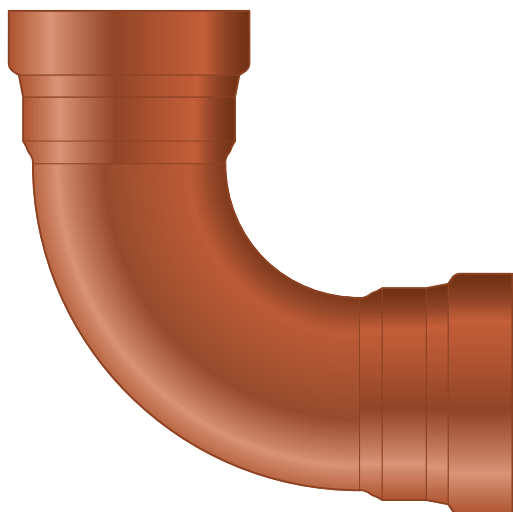
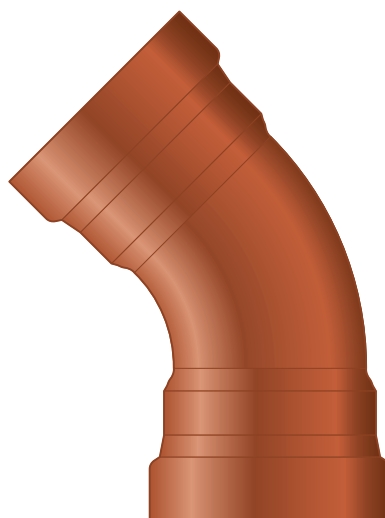
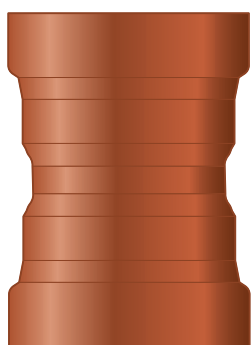

Press connector system made of copper for copper pipes

System
Profipress XL

Year built (from)
01/1998

viega

Table of contents

1	About these instructions for use	3
	1.1 Target groups	3
	1.2 Labelling of notes	3
	1.3 About this translated version	4
2	Product information	5
	2.1 Standards and regulations	5
	2.2 Intended use	7
	2.2.1 Areas of use	7
	2.2.2 Media	8
	2.3 Product description	8
	2.3.1 Overview	8
	2.3.2 Pipes	8
	2.3.3 Press connectors	11
	2.3.4 Sealing elements	13
	2.3.5 Mixed installations	14
	2.4 Information for use	14
	2.4.1 Corrosion	14
3	Handling	15
	3.1 Transport	15
	3.2 Storage	15
	3.3 Assembly information	15
	3.3.1 Mounting instructions	15
	3.3.2 Potential equalisation	16
	3.3.3 Permitted exchange of sealing elements	16
	3.3.4 Space requirements and intervals	17
	3.3.5 Required tools	18
	3.4 Assembly	19
	3.4.1 Replacing the sealing element	19
	3.4.2 Shortening the pipes	20
	3.4.3 Deburring the pipes	20
	3.4.4 Pressing the connection	21
	3.4.5 Leakage test	23
	3.5 Maintenance	23
	3.6 Disposal	23

1 About these instructions for use

Trade mark rights exist for this document; for further information, go to viega.com/legal.

1.1 Target groups

The information in this manual is directed at heating and sanitary professionals and trained personnel.

Individuals without the abovementioned training or qualification are not permitted to mount, install and, if required, maintain this product. This restriction does not extend to possible operating instructions.

The installation of Viega products must take place in accordance with the general rules of engineering and the Viega instructions for use.

1.2 Labelling of notes

Warning and advisory texts are set aside from the remainder of the text and are labelled with the relevant pictographs.



DANGER!

This symbol warns of possible life-threatening injury.



WARNING!

This symbol warns of possible serious injury.



CAUTION!

This symbol warns of possible injury.



NOTICE!

This symbol warns of possible damage to property.



This symbol gives additional information and hints.

1.3 About this translated version

This instruction for use contains important information about the choice of product or system, assembly and commissioning as well as intended use and, if required, maintenance measures. The information about the products, their properties and application technology are based on the current standards in Europe (e.g. EN) and/or in Germany (e.g. DIN/DVGW).

Some passages in the text may refer to technical codes in Europe/Germany. These should serve as recommendations in the absence of corresponding national regulations. The relevant national laws, standards, regulations, directives and other technical provisions take priority over the German/European directives specified in this manual: The information herein is not binding for other countries and regions; as said above, they should be understood as a recommendation.

2 Product information

2.1 Standards and regulations

The following standards and regulations apply to Germany / Europe and are provided as a support feature.

Regulations from section: Fields of application

Scope / Notice	Regulations applicable in Germany
Application in fire extinguishing systems	DIN 14462
Planning, execution, operation and maintenance of potable water installations	DIN EN 1717
Planning, execution, operation and maintenance of potable water installations	DIN 1988
Planning, execution, operation and maintenance of potable water installations	VDI/DVGW 6023
Planning, execution, operation and maintenance of potable water installations	Trinkwasserverordnung (TrinkwV)

Regulations from section: Media

Scope / Notice	Regulations applicable in Germany
Suitability for potable water	Trinkwasserverordnung (TrinkwV)
Suitability for heating water for pump hot water heating systems	VDI-Richtlinie 2035, Sheet 1 and Sheet 2

Regulations from section: Pipes

Scope / Notice	Regulations applicable in Germany
Permitted copper pipes	DIN EN 1057
Approval of press connectors for use with copper pipes	DVGW-Arbeitsblatt GW 392

Regulations from section: Sealing elements

Scope / Notice	Regulations applicable in Germany
Area of use of the EPDM sealing element ■ Heating	DIN EN 12828

Regulations from section: Corrosion

Scope / Notice	Regulations applicable in Germany
Regulations for external corrosion protection	DIN EN 806-2
Regulations for external corrosion protection	DIN 1988-200
Regulations for external corrosion protection	DKI-Informationsdruck i. 160

Regulations from section: Storage

Scope / Notice	Regulations applicable in Germany
Requirements for material storage	DIN EN 806-4, Chapter 4.2

Regulations from section: Leakage test

Scope / Notice	Regulations applicable in Germany
Test on a system that is finished but not yet covered	DIN EN 806-4
Leakage test for water installations	ZVSHK-Merkblatt: "Dichtheitsprüfungen von Trinkwasserinstallationen mit Druckluft, Inertgas oder Wasser"

Regulations from section: Maintenance

Scope / Notice	Regulations applicable in Germany
Operation and maintenance of potable water installations	DIN EN 806-5

2.2 Intended use



Coordinate the use of the system for areas of use and media other than those described with the Viega Service Center.

2.2.1 Areas of use

Use is possible in the following areas among others:

- Potable water installations
- Industrial and heating systems
- Fire extinguishing systems, see [☞ „Regulations from section: Fields of application“ on page 5](#)
 - wet
- Solar installations with flat collectors
- Solar installations with vacuum collectors (only with FKM sealing element)
- Compressed air systems
- District heat supply systems (only with FKM sealing element)
- Low-pressure steam systems (only with FKM sealing element)
- Cooling water pipelines (closed circuit)

Potable water installation

For planning, execution, operation and maintenance of potable water installations, observe the applicable regulations, see [☞ „Regulations from section: Fields of application“ on page 5](#).

Maintenance

Inform your customer or the operator of the potable water installation that the system has to be maintained on a regular basis, see [☞ Chapter 3.5 „Maintenance“ on page 23](#).

Sealing element

Only EPDM sealing elements are approved in potable water installations. Do not use any other sealing elements.

2.2.2 Media

The system is suitable for the following media, amongst others:

For the applicable directives, see ↗ „Regulations from section: Media“ on page 5.

- Potable water in respect of the pipe material, except the components (press connectors, fittings, devices, etc.):
- Heating water for pump hot water heating systems
- Compressed air in compliance with the specification of the sealing elements being used
 - EPDM at oil concentration < 25 mg/m³
 - FKM at oil concentration ≥ 25 mg/m³
- Anti-freeze, cooling brines up to a concentration of 50 %
- Steam in low-pressure steam systems (only with FKM sealing element)

2.3 Product description

2.3.1 Overview

The piping system consists of press connectors for copper pipes and the corresponding press tools.

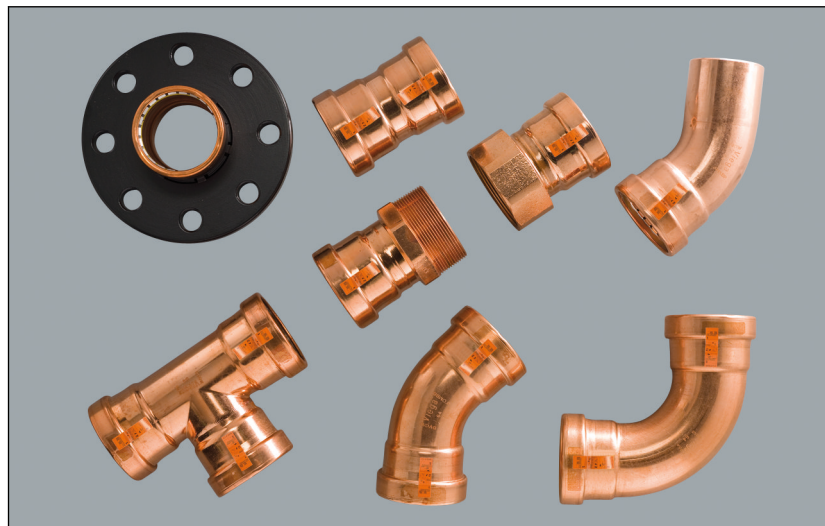

Fig. 1: Press connector and flange

The system components are available in the following dimensions:
d 64.0 / 66.7 / 76.1 / 88.9 / 108.0.

2.3.2 Pipes

Only copper pipes that comply with the pertinent regulations may be used, see ↗ „Regulations from section: Pipes“ on page 5:

Various wall thicknesses are permitted depending on the area of use (potable water or heating installation).

Certified copper pipes in potable water installations

d x s [mm]	Volume per metre of pipe [l/m]	Pipe weight [kg/m]
64.0 x 2.0	2.83	3.47
66.7 x		
76.1 x 2.0	4.08	4.14
88.9 x 2.0	5.66	4.86
108.0 x 2.5	8.33	7.37

Certified copper pipes in heating installations

d x s [mm]	Volume per metre of pipe [l/m]	Pipe weight [kg/m]
64.0 x 2.0	2.83	3.47
66.7		
76.1 x 2.0	4.08	4.14
88.9 x 2.0	5.66	4.86
108.0 x 2.5	8.33	7.37

Profipress press connectors can be combined with the Viega Inox industrial pipe 1.4520. The Inox 1.4520 industrial pipe is not approved for potable water and gas installations. The exact areas of use are stated in the document entitled "Areas of Use of Metal Installation Systems" or agreed in consultation with the Viega Service Center.

Pipe key data for Inox industrial pipe 1.4520

d x s [mm]	Volume per metre of pipe [l/m]	Pipe weight [kg/m]
64.0 x 1.5	2.92	2.35

Laying and fixing pipes

Only pipe clamps with noise insulation inlays should be used.

Observe the general rules of fixing technology:

- Fixed pipelines should not be used as support for other pipelines and components.
- Do not use pipe hooks.
- Observe distance to connectors.
- Observe the expansion direction – plan fixed and gliding points.

Affix the pipelines in such a way as to de-couple them from the installation body, so that they cannot transfer any structure-borne sound, resulting from thermal expansion or possible pressure surges, onto the installation body or other components.

Observe the following fixing intervals:

Interval between the pipe clamps

d [mm]	Fixing interval between the pipe clamps [m]
64.0	4.00
66.7	
76.1	4.25
88.9	4.75
108.0	5.00

Length expansion

Pipelines expand with heat. Heat expansion is dependent on the material. Changes in length lead to tension within the installation. These tensions must be equalised with suitable measures.

The following are effective:

- Fixed and gliding points
- Expansion equalisation joints (expansion bends)
- Compensators

Heat expansion co-efficient

Material	Heat expansion co-efficient α [mm/mK]	Example: Length expansion with pipe lengths = 20 m and $\Delta T = 50$ K [mm]
Copper	0.0166	16.6
Stainless steel 1.4520	0.0165	16.5

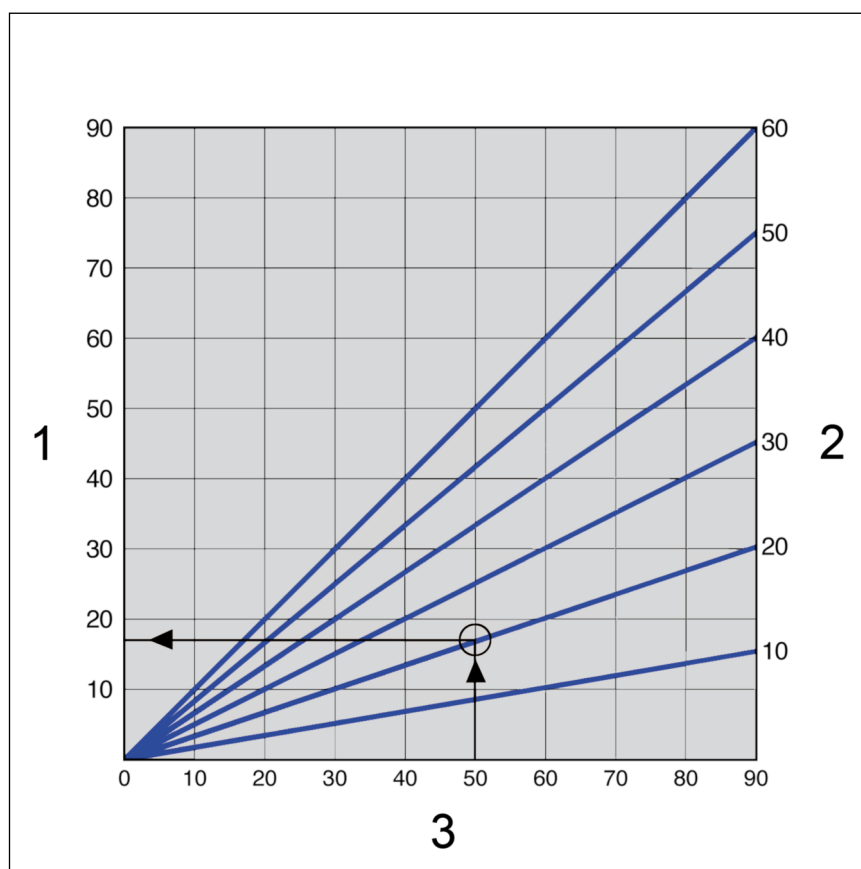

Fig. 2: Length expansion of copper pipes

- 1 - Length expansion $\vec{\Delta}l$ [mm]
- 2 - Pipe length \vec{l}_0 [m]
- 3 - Temperature difference $\vec{\Delta}\vartheta$ [K]

The length expansion Δl can be taken from the diagram or can be calculated using the following formula:

$$\Delta l = \alpha \text{ [mm/mK]} \times L \text{ [m]} \times \Delta\vartheta \text{ [K]}$$

2.3.3 Press connectors

Press connectors are available in a number of shapes. An overview of the press connectors suitable for the system can be found in the catalogue.

The press connectors in the Profipress XL system are made of copper.



Fig. 3: Press connectors

On Profipress XL press connectors, there is a cutting ring, a separator ring and a sealing element in the bead of the press connector. The cutting ring cuts into the pipe during pressing and ensures a force-fit connection.

During installation, and later during the pressing, the separator ring protects the sealing element from damage from the cutting ring.

SC-Contur

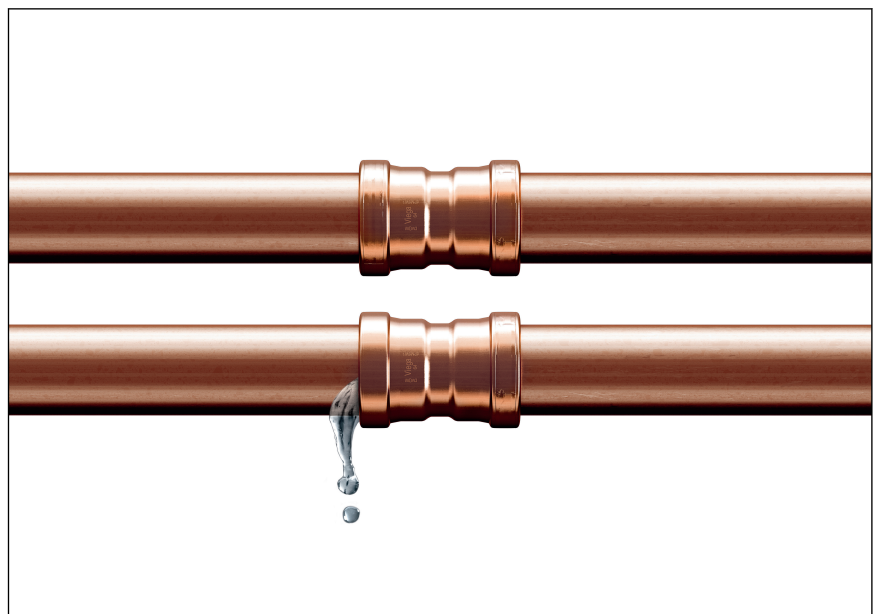

Fig. 4: SC-Contur

Viega press connectors are equipped with the SC-Contur. The SC-Contur is a safety technology that is certified by the DVGW and ensures that the press connector is guaranteed to be leaky in an unpressed state. In this way, inadvertently unpressed connections are noticed immediately when filling the system.

Viega ensures that connections inadvertently unpressed during installation become visible when the system is filled:

- with the wet leakage test in the pressure range from 0.1–0.65 MPa (1.0–6.5 bar)
- with dry leakage test in the pressure range from 22 hPa–0.3 MPa (22 mbar–3.0 bar)

2.3.4 Sealing elements

The press connectors are factory-fitted with EPDM sealing elements. For areas of use with higher thermal resistance, such as e.g. in the case of district heat supply or low-pressure steam systems, the press connectors must be equipped with FKM sealing elements.

The sealing elements can be distinguished as follows:

- EPDM sealing elements are polished black.
- FKM sealing elements are matt black.

Area of use of the EPDM sealing element

Area of use	Potable water	Heating	Solar installations	Compressed air	Technical gases
Area of use	all pipeline sections	Pump hot water heating system	Solar circuit	all pipeline sections	all pipeline sections
Operating temperature [T _{max.}]	110 °C	110 °C	1)	60 °C	—
Operating pressure [P _{max.}]	1.6 MPa (16 bar)	1.6 MPa (16 bar)	0.6 MPa (6 bar)	1.6 MPa (16 bar)	—
Comments	see notes ↳ Chapter 2.2.2 „Media“ on page 8	T _{max} 105 °C ²⁾ 95 °C with radiator connection	for flat collectors	dry, oil content < 25 mg / m ³	1)

1) Consultation with the Viega Service Center required.

2) see ↳ „Regulations from section: Sealing elements“ on page 6

Area of use of the FKM sealing element

Area of use	District heat supply	Solar installations	Compressed air
Use	District heat supply systems behind the external wall lead-in	Solar circuit	all pipeline sections
Operating temperature [T _{max.}]	140 °C	1)	60 °C
Operating pressure [P _{max.}]	1.6 MPa (16 bar)	0.6 MPa (6 bar)	1.6 MPa (16 bar)
Comments	—	—	dry, oil content ≥ 25 mg / m ³

1) Consultation with the Viega Service Center required.

2.3.5 Mixed installations

In potable water installations, piping components from different metals can have a detrimental effect on each other and cause corrosion, for example. For instance, a copper pipe must not be installed directly upstream of a galvanised steel pipe.



The flow rule must be observed in all mixed installations with pipes made of copper and galvanised steel.

Please contact the Viega Service Center if you have any questions on this subject.

2.4 Information for use

2.4.1 Corrosion

Overground pipelines and fittings in rooms do not normally require external corrosion protection.

There are exceptions in the following cases:

- Contact with aggressive building materials such as nitrite or materials containing ammonium
- in aggressive surroundings

If external corrosion protection is required, observe the pertinent guidelines, see ↗ „Regulations from section: Corrosion“ on page 6.

3 Handling

3.1 Transport

Observe the following when transporting pipes:

- Do not pull the pipes over the sill. The surface could be damaged.
- Secure pipes during transportation. Pipes may become bent due to shifting.
- Do not damage the protective caps on the pipe ends and do not remove them until immediately before mounting. Damaged pipe ends may not be pressed.



In addition, observe the instructions provided by the pipe manufacturer.

3.2 Storage

For storage, comply with the requirements specified in the applicable regulations, see [☞ „Regulations from section: Storage“ on page 6:](#)

- Store components in a clean and dry place.
- Do not store the components directly on the floor.
- Provide at least three points of support for the storage of pipes.
- Where possible, store different sizes separately.
Store small sizes on top of larger sizes if separate storage is not possible.



In addition, observe the instructions provided by the pipe manufacturer.

3.3 Assembly information

3.3.1 Mounting instructions

Checking system components

System components may, in some cases, become damaged through transportation and storage.

- Check all parts.
- Replace damaged components.
- Do not repair damaged components.
- Contaminated components may not be installed.

3.3.2 Potential equalisation



DANGER! **Danger due to electrical current**

An electric shock can lead to burns and serious injury and even death.

Because all metallic piping systems conduct electricity, unintentional contact with a live part can lead to the whole piping system and components connected to it (e. g. radiators) becoming energised.

- Only allow electrical work to be carried out by qualified electricians.
- Always integrate the metal piping system into the potential equalisation.



It is the fitter of the electrical system who is responsible for ensuring that the potential equalisation is tested and secured.

3.3.3 Permitted exchange of sealing elements



Important instruction

With their material-specific qualities, sealing elements in press connectors are adapted for use with the corresponding media and/or the areas of use of the piping systems and are generally only certified for them.

The exchange of a sealing element is generally permitted. The sealing element must be exchanged for a designated spare part for the intended application ↪ *Chapter 2.3.4 „Sealing elements“ on page 13*. The use of other sealing elements is not permitted.

Exchanging a sealing element is permitted in the following situations:

- if the sealing element in the press connector is obviously damaged and should be exchanged for a Viega spare sealing element made of the same material
- if an EPDM sealing element should be exchanged for an FKM sealing element (higher thermal resistance, e.g. for industrial use)

3.3.4 Space requirements and intervals

Pressing between pipelines

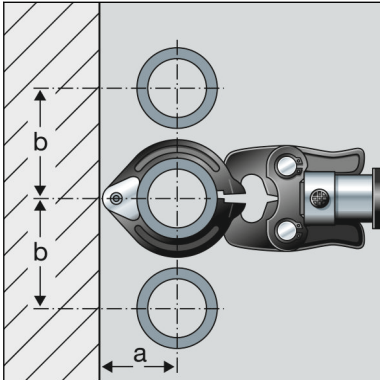

d	64.0	66.7	76.1	88.9	108.0
a [mm]	110	110	110	120	135
b [mm]	185	185	185	200	215

Pressing between pipe and wall

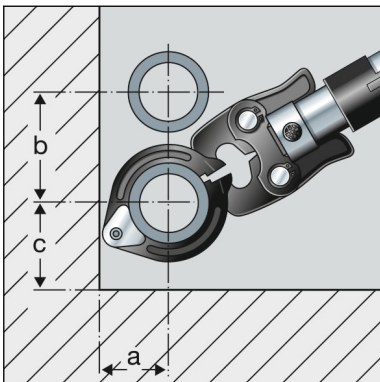

d	64.0	67.7	76.1	88.9	108.0
a [mm]	110	110	120	120	135
b [mm]	185	185	200	200	215
c [mm]	130	130	140	140	155

Distance to walls

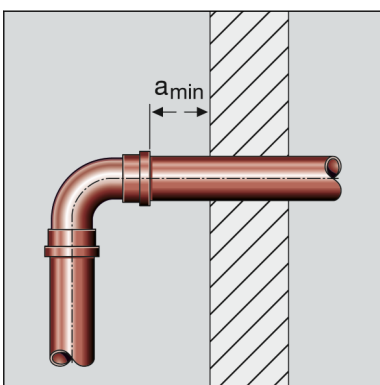

d	64.0–108.0
Minimum interval a_{min} [mm]	20

Interval between the pressings



NOTICE!

Leaky press connections due to pipes being too short

If two press connectors are to be mounted next to one another onto a pipe without an interval, the pipe must not be too short. If the pipe is not inserted up to the prescribed insertion depth in the press connector during pressing, the connection may become leaky.

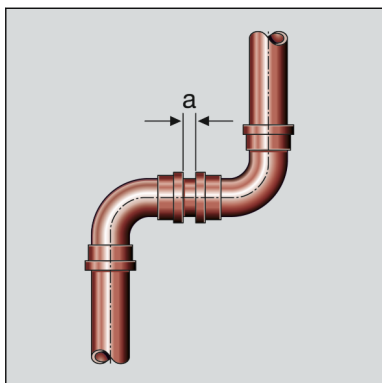

d	64.0–108.0
Minimum interval a [mm]	15

Z dimensions

For the Z dimensions, refer to the respective product page in the online catalogue.

3.3.5 Required tools

The following tools are required for production of a press connection:

- pipe cutter or a fine-toothed hacksaw
- deburrer and coloured pen for marking
- press machine with constant pressing force of 32 kN
- Press ring with corresponding hinged adapter jaw, suitable for the pipe diameter and suitable profile

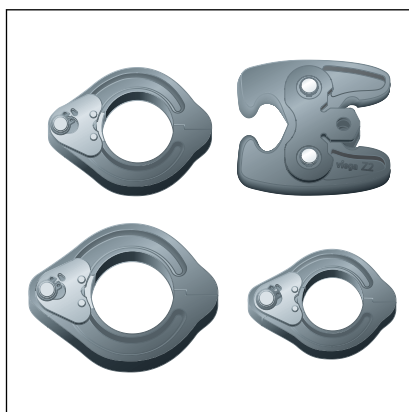

Fig. 5: Press rings and hinged adapter jaw

Recommended Viega press machines:

- Pressgun 5
- Pressgun 4E / 4B
- Type PT3-AH
- Type PT3-H / EH
- Type 2 (PT2)

3.4 Assembly

3.4.1 Replacing the sealing element

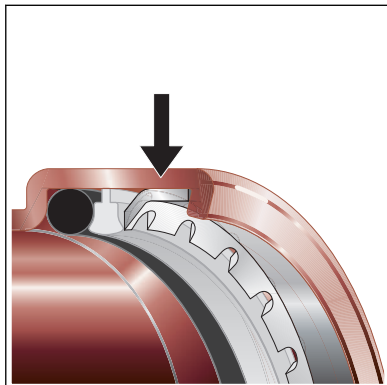

Fig. 6: Cutting ring



CAUTION!
Risk of injury due to sharp edges

There is a separator ring and a sharp-edged cutting ring above the sealing element (see arrow). There is a risk of injury (cutting) when replacing the sealing element.

- Do not reach into the press connector with your bare hands.

Removing the sealing element



Do not use pointed or sharp-edged objects to remove the sealing element. They may damage the sealing element or the bead.

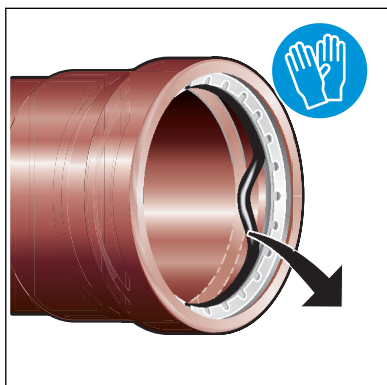

- Remove the sealing element from the bead, leaving the separator ring in the press connector.

Proceed carefully to avoid damaging the separator ring and sealing element seat.

Inserting the sealing element

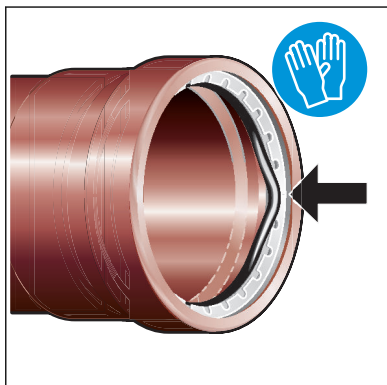

- Insert a new, undamaged sealing element into the bead below the separator ring.

Make sure that the sealing element is not damaged by the cutting ring.

- Ensure that the complete sealing element is in the bead.

3.4.2 Shortening the pipes



NOTICE! **Leaky press connections due to damaged material!**

Press connections can become leaky due to damaged pipes or sealing elements.

Observe the following instructions to avoid damage to pipes and sealing elements:

- Do not use cutting discs (angle grinders) or flame cutters when cutting to length.
- Do not use grease or oils (e. g. cutting oil).

For information about tools, also see [Chapter 3.3.5 „Required tools“](#) on page 18.

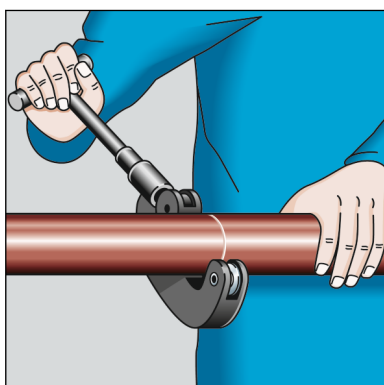

- Cut the pipe properly using a pipe cutter or fine-toothed hacksaw. Avoid grooves on the pipe surface.

3.4.3 Deburring the pipes

The pipe ends must be thoroughly deburred internally and externally after shortening.

Deburring prevents the sealing element being damaged or the that the press connector cants when mounted. Viega recommends using a deburrer (model 2292.4XL).



NOTICE! **Damage due to the wrong tool!**

Do not use sanding disks or similar tools when deburring. The pipes could be damaged by these.

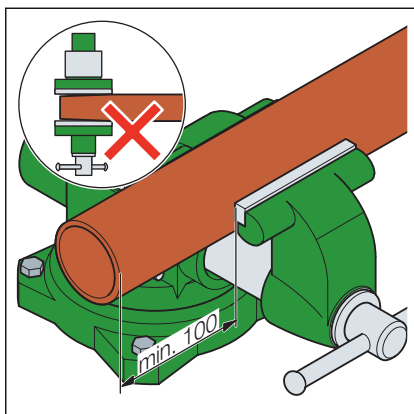

- Secure the pipe in the vice.
- When securing, leave an interval of at least 100 mm (a) to the pipe end.
The pipe ends must not be bent or damaged.

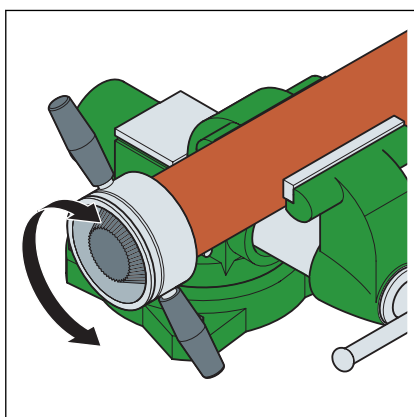

- Deburr the inside and outside of the pipe.

3.4.4 Pressing the connection

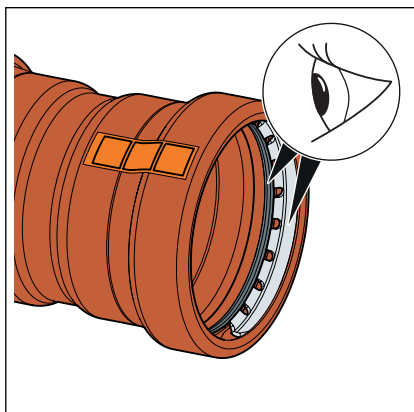

Requirements:

- The pipe end is not bent or damaged.
- The pipe is deburred.
- The correct sealing element is in the press connector.
EPDM = polished black
FKM = matt black

- Sealing element, separator ring and cutting ring are undamaged.
- The complete sealing element, separator ring and cutting ring are in the bead.

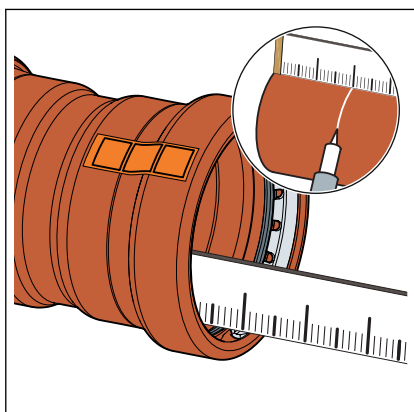

- Measure insertion depth in the connector.

d [mm]	Insertion depth [mm]
64.0	43
66.7	43
76.1	50
88.9	50
108.0	60

- Mark the insertion depth on the pipe

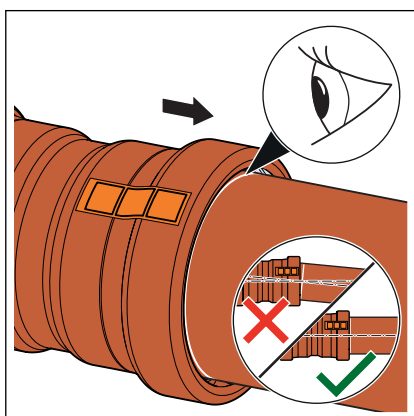

- Push the press connector up to the marked insertion depth on the pipe. Do not twist the press connector.
- Place the hinged adapter jaw onto the press machine and push the retaining bolt in until it clicks into place.

INFO! Observe the press tool instruction manual.

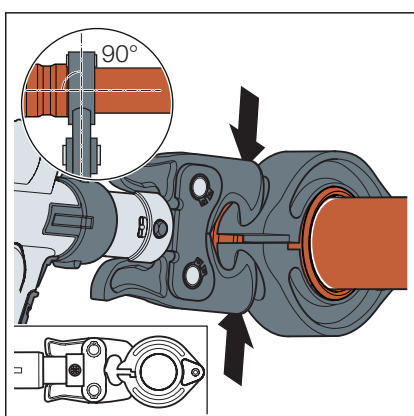

- Place the press ring onto the press connector. The press ring must completely cover the outside ring of the press connector.
- Open the hinged adapter jaw.
- Position the hinged adapter jaw into the seat of the press ring.
- Carry out the pressing process.
- Open the hinged adapter jaw and remove the press ring.

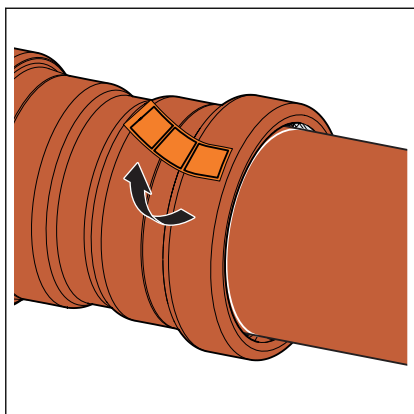

- Remove the checking strip.
- ◻ The connection is marked as having been pressed.

3.4.5 Leakage test

The installer must perform a leakage test before commissioning.

Carry out this test on a system that is finished but not covered yet.

Observe the applicable regulations, see ↗ „Regulations from section: Leakage test“ on page 6.

The leakage test pursuant to the applicable regulations must also be carried out for non-potable water installations, see ↗ „Regulations from section: Leakage test“ on page 6.

Document the result.

3.5 Maintenance

Observe the applicable regulations for the operation and maintenance of potable water installations, see ↗ „Regulations from section: Maintenance“ on page 6.

3.6 Disposal

Separate the product and packaging materials (e. g. paper, metal, plastic or non-ferrous metals) and dispose of in accordance with valid national legal requirements.



Viega Technology GmbH & Co. KG

service-technik@viega.de

viega.com

INT • 2020-02 • VPN190489

